

dimensions in mm

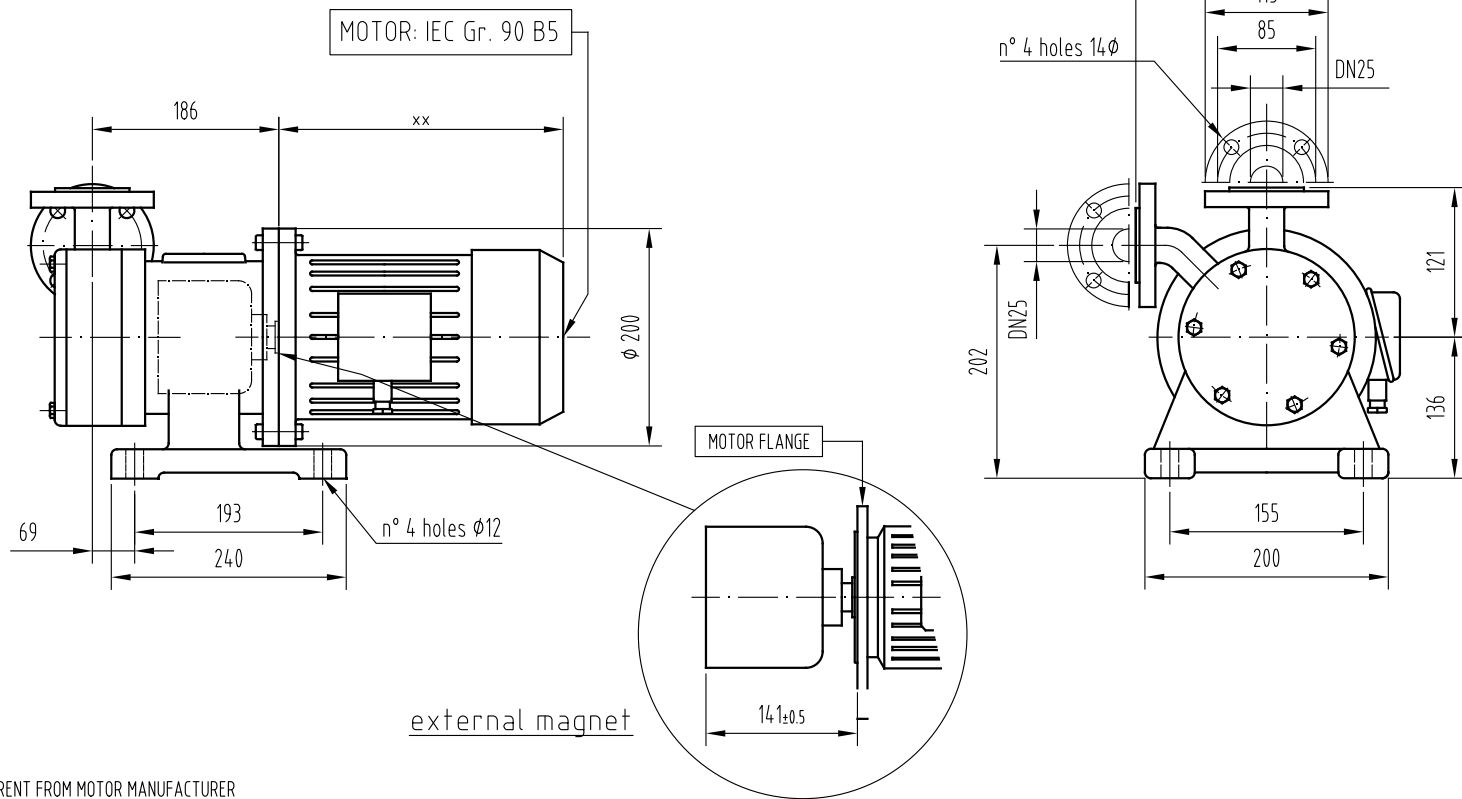

xx DIFFERENT FROM MOTOR MANUFACTURER  
- DIRECTION AND PORTS LOCATION ARE REVERSIBLE

FLANGES DIN 2633 PN 16

REF	DESCRIPTION	MATERIAL	CODE
10	Containment shell		
20	Ext. Magnet		
30	Int. Magnet		
40	Impeller		
50	Set O-Rings (a+b+c) a + b = O-Ring 4337 (237) c = O-Ring 4400 (242)		
61	Thrust Bearings		
62	Rear Ring		
70	Shaft		
75	Sleeve Bearings Bearings (d+e) Bearing (f)		
78	Bracket (200-130-24)		
79	Rub Ring		
84	End Cover		
85	Pump Casing		
88	Rear Wet End (10+30+40+50+61+62+70+75)		

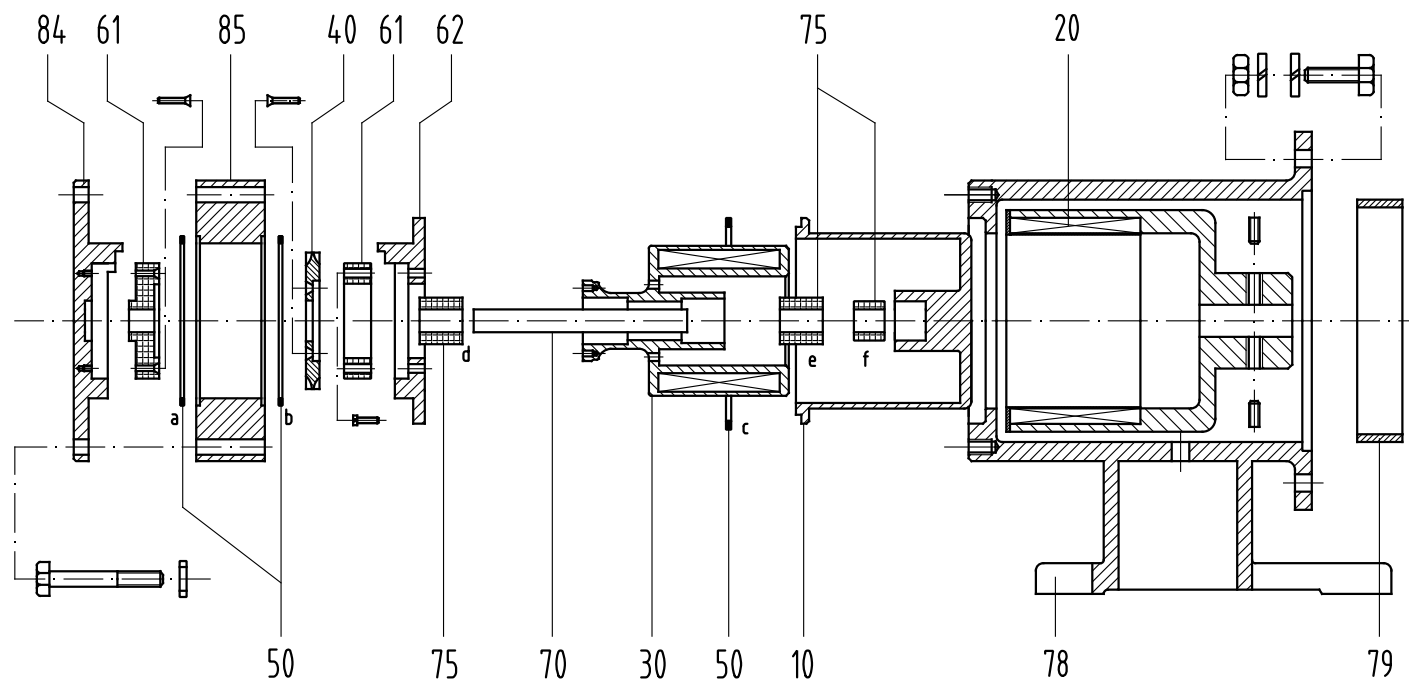

**MARCH PUMPEN GmbH & Co.KG**  
 Rathenastraße 2  
 D-35394 Gießen  
 www.march-pumpen.com  
 info@march-pumpen.com

Baureihe / Series:	MTA
Typ / Type:	MTA 49 SSF
Motor:	IEC 90 B5